



NO-B1 Nitric Oxide Sensor



PATENTED

Figure 1 NO-B1 Schematic Diagram

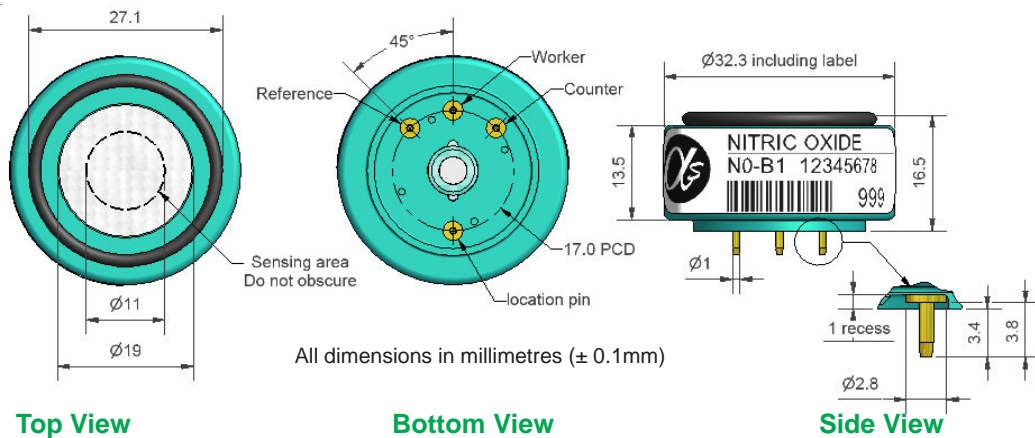

Technical Specification

PERFORMANCE	Sensitivity	nA/ppm in 50ppm NO	400 to 660
	Response time	t ₉₀ (s) from zero to 50ppm NO	< 20
	Zero current	ppm equivalent in zero air	0 to +3
	Resolution	RMS noise (ppm equivalent)	< 0.15
	Range	ppm NO limit of performance warranty	250
	Linearity	ppm error at full scale, linear at zero and 50ppm NO	-20 to -25
	Overtask limit	maximum ppm for stable response to gas pulse	1200
LIFETIME	Zero drift	ppm equivalent change/year in lab air	<0.3
	Sensitivity drift	% change/year in lab air, monthly test	<5
	Operating life	months until 80% original signal (24 month warranted)	> 24
ENVIRONMENTAL	Sensitivity @ -20°C	% (output @ -20°C/output @ 20°C) @ 50ppm NO	87 to 95
	Sensitivity @ 50°C	% (output @ 50°C/output @ 20°C) @ 50ppm NO	102 to 107
	Zero @ -20°C	ppm equivalent change from 20°C	± 1
	Zero @ 50°C	ppm equivalent change from 20°C	6 to 10
CROSS SENSITIVITY	H ₂ S sensitivity	% measured gas @ 20ppm	< 60
	NO ₂ sensitivity	% measured gas @ 10ppm	< 5
	Cl ₂ sensitivity	% measured gas @ 10ppm	< 5
	SO ₂ sensitivity	% measured gas @ 20ppm	< 4
	H ₂ sensitivity	% measured gas @ 400ppm	< 0.1
	CO sensitivity	% measured gas @ 400ppm	< 0.1
	NH ₃ sensitivity	% measured gas @ 20ppm	< 0.1
CO ₂ sensitivity	% measured gas @ 5% Vol	< 0.1	

KEY SPECIFICATIONS

Bias voltage	mV (working electrode potential is above ground)	+300
Temperature range	°C	-30 to 50
Pressure range	kPa	80 to 120
Humidity range	% rh continuous	15 to 90
Storage period	months @ 3 to 20°C (stored in sealed pot)	6
Load resistor	Ω (recommended)	10 to 47
Weight	g	< 13



At the end of the product's life, do not dispose of any electronic sensor, component or instrument in the domestic waste, but contact the instrument manufacturer, Alphasense or its distributor for disposal instructions.

NOTE: all sensors are tested at ambient environmental conditions, with 10 ohm load resistor, unless otherwise stated. As applications of use are outside our control, the information provided is given without legal responsibility. Customers should test under their own conditions, to ensure that the sensors are suitable for their own requirements.



NO-B1 Performance Data

Technical Specification

Figure 2 Sensitivity Temperature Dependence

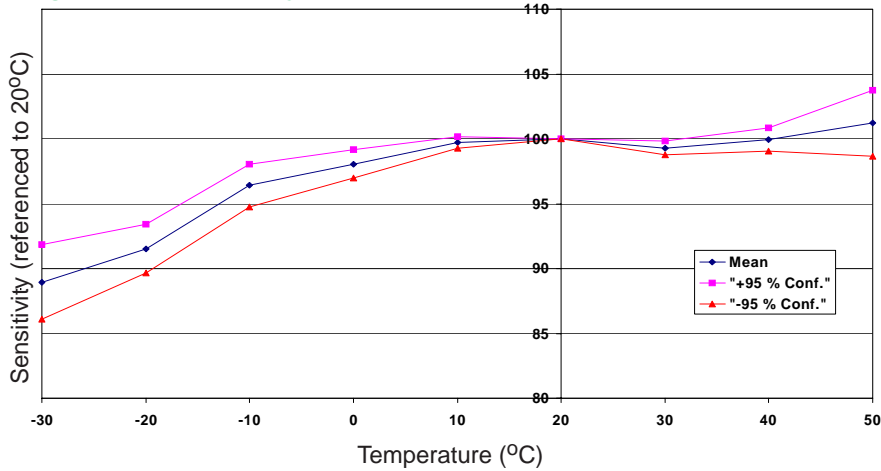

Figure 2 shows the variation in sensitivity caused by changes in temperature.

This data is taken from a typical batch of sensors. The mean and $\pm 95\%$ confidence intervals are shown.

Figure 3 Zero Temperature Dependence

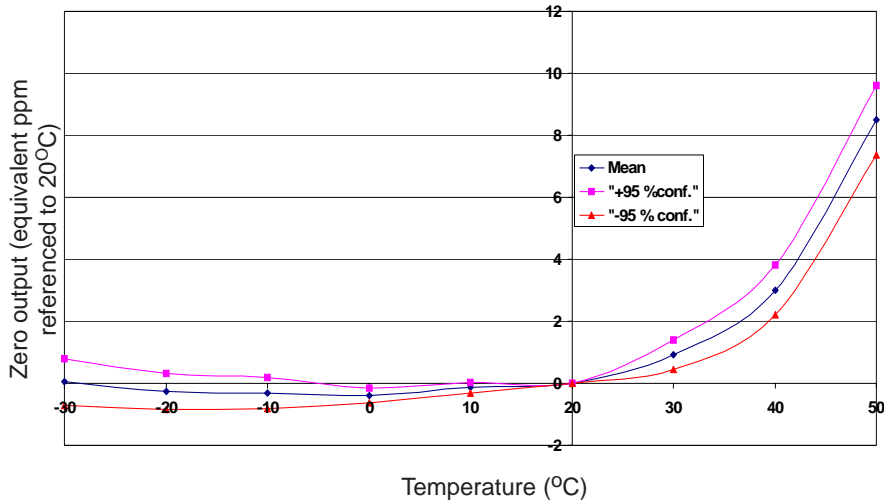
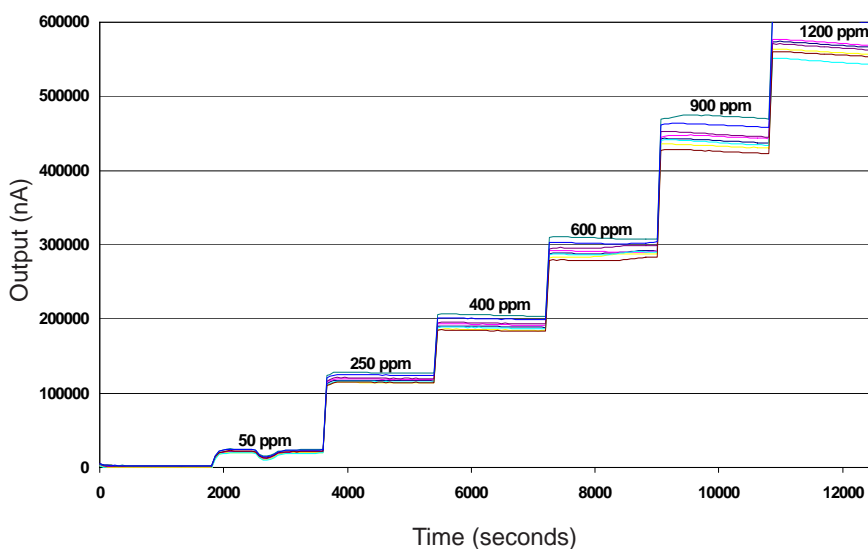

Figure 3 shows the variation in zero output caused by changes in temperature expressed as ppm gas equivalent.

This data is taken from a typical batch of sensors. The mean and $\pm 95\%$ confidence intervals are shown.

Figure 4 NO-B1 Response to 1200ppm NO



The NO-B1 responds rapidly to gas concentrations up to 1200ppm NO.

This data is taken from a typical batch of sensors.

For further information on the performance of this sensor, on other sensors in the range or any other subject, please contact Alphasense Ltd. For Application Notes visit "www.alphasense.com".

In the interest of continued product improvement, we reserve the right to change design features and specifications without prior notification. The data contained in this document is for guidance only. Alphasense Ltd accepts no liability for any consequential losses, injury or damage resulting from the use of this document or the information contained within. (©ALPHASENSE LTD) Doc. Ref. NOB1/FEB09