



# 7HL CiTiceL<sup>®</sup>

## Performance Characteristics

<b>Nominal Range</b>	0-50ppm
<b>Maximum Overload</b>	100ppm
<b>Expected Operating Life</b>	Two years in air
<b>Output Signal</b>	0.75 ± 0.25 µA/ppm
<b>Resolution</b>	0.5ppm
<b>Temperature Range</b>	-20°C to +50°C
<b>Pressure Range</b>	Atmospheric ± 10%
<b>Pressure Coefficient</b>	No data
<b>T<sub>90</sub> Response Time</b>	≤120 seconds (typically 100)
<b>Relative Humidity Range</b>	15 to 90% non-condensing
<b>Typical Baseline Range (pure air)</b>	0 to +2ppm
<b>Maximum Zero Shift (+20°C to +40°C)</b>	4ppm equivalent
<b>Long Term Output Drift</b>	<2% signal loss/month
<b>Recommended Load Resistor</b>	33Ω
<b>Bias Voltage</b>	+300mV
<b>Repeatability</b>	2% of signal
<b>Output Linearity</b>	Linear

N.B. All performance data is based on conditions at 20°C, 50%RH, and 1013mBar

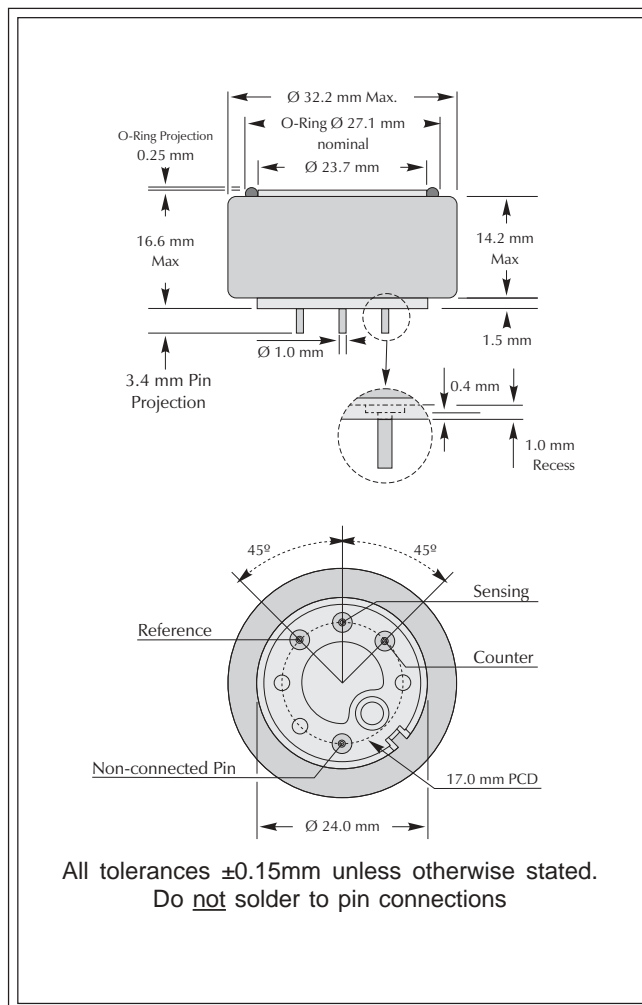

## Physical Characteristics

<b>Weight</b>	17g
<b>Position Sensitivity</b>	None
<b>Storage Life</b>	Six months in CTL container
<b>Recommended Storage Temperature</b>	0-20°C
<b>Warranty Period</b>	12 months from date of despatch

**IMPORTANT NOTE:** Connection should be made via PCB sockets only. Soldering to the pins will render your warranty void.



**7HL Hydrogen chloride CiTiceL - Output vs Temperature**

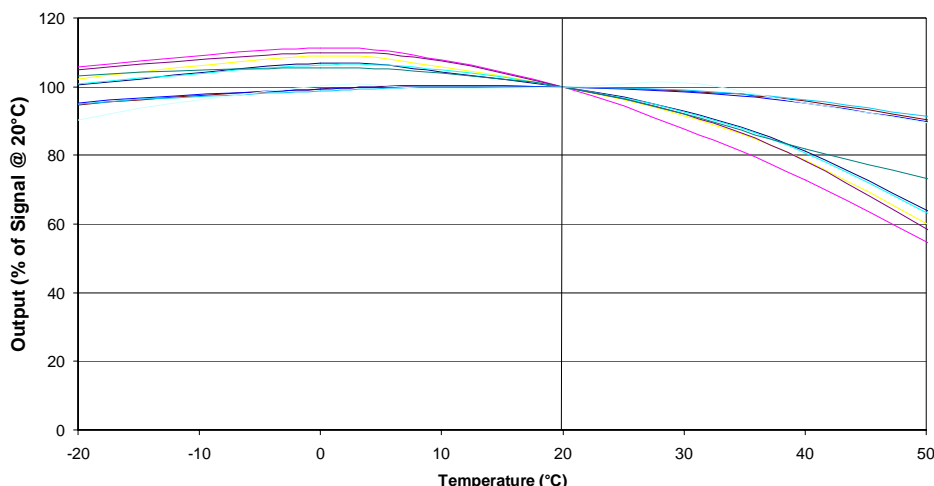

## Cross-sensitivity Data

CiTiceLs may exhibit a response to certain gases in a sample other than the target gas. 7HL CiTiceLs have been tested with a number of commonly cross-interfering gases and the results are given below. The table shows the typical response to be expected from a sensor when exposed to a given test gas concentration (relevant to safety, e.g. TLV levels).

<u>Gas</u>	<u>Conc.</u>	<u>7HL</u>	<u>Gas</u>	<u>Conc.</u>	<u>7HL</u>
<b>Carbon monoxide:</b>	300ppm	<3ppm	<b>Chlorine:</b>	1ppm	-0.05<x\$<0.1ppm
<b>Hydrogen sulphide:</b>	15ppm	27<x\$<45ppm	<b>Hydrogen:</b>	100ppm	<0.5ppm
<b>Sulphur dioxide:</b>	5ppm	1.5<x\$<3.5ppm	<b>Hydrogen cyanide:</b>	10ppm	<0.3ppm
<b>Nitric oxide:</b>	35ppm	0ppm	<b>Ethylene:</b>	100ppm	<6ppm
<b>Nitrogen dioxide:</b>	5ppm	0.5<x\$<1ppm	**For details of other possible cross-interfering gases contact City Technology.**		

**Ordering Information:**  
**Also available with bias board (7BHL)**

Every effort has been made to ensure the accuracy of this document at the time of printing. In accordance with the company's policy of continued product improvement City Technology Limited reserves the right to make product changes without notice. No liability is accepted for any consequential losses, injury or damage resulting from the use of this document or from any omissions or errors herein. The data is given for guidance only. It does not constitute a specification or an offer for sale. The products are always subject to a programme of improvement and testing which may result in some changes in the characteristics quoted. As the products may be used by the client in circumstances beyond the knowledge and control of City Technology Limited, we cannot give any warranty as to the relevance of these particulars to an application. It is the clients' responsibility to carry out the necessary tests to determine the usefulness of the products and to ensure their safety of operation in a particular application.

Performance characteristics on this data sheet outline the performance of newly supplied sensors. Output signal can drift below the lower limit over time.